

RJ45 CAT5E SHIELDED 24-PORT LOADED PATCH PANEL (110 & KRONE)

SKUS PP-4524S

FEATURES

- Shielded 1U 24-Port Loaded RJ45 Category 5E Patch Panel 19", with T568A/B colour coded wiring patterns
- Use 110 punch-down tool with provided keystones and IDC cap for terminating shielded 22-26 AWG Cat5E shielded cable
- Rack-mountable, fits within any standard 19" rack or cabinet
- Ideal for indoor networking installations in environments with high Electromagnetic Interference or Radio Frequency Interference (EMI/RFI)
- Labels on the front provide space for adding identification, with an additional port numbering system on the front and rear of the patch panel
- Gold plated contacts for superior transmission, high reliability and durability
- Meets EIA/TIA 568B, ISO/IEC 11801 standards, Third Party Tested, cETLus Intertek listed, and RoHS compliant
- Wire on rear of patch panel for grounding



AVAILABLE COLOURS



SIZE (WxDxH) 482 x 115.4 x 44 mm

MATERIALS

PANEL	Metal (SPCC)
PANEL COVER	Aluminum
JACK	8P8C 50 Micro-inches gold plated
PCB	FR-4 / UL-94V0
IDC BODY	Fireproof ABS UL-94V0
IDC PIN	Bronze & Tinned
IDC DESCRIPTION	For 22-26 AWG For 110 punch-down tool

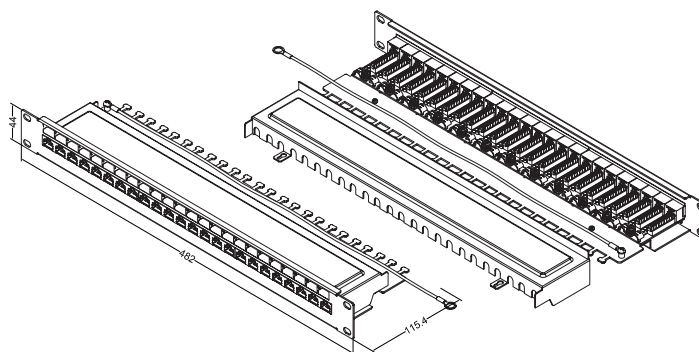

SPECIFICATIONS

UL APPROVED 3P THIRD PARTY TESTED ROHS COMPLIANT		INSULATION RESISTANCE	500M ohms (min.)
MEETS C5E EIA/TIA 568B STANDARD CETLUS CERTIFIED		CONTACT RESISTANCE	20m ohms (max.)
IDC PUNCH DOWN CYCLE	Over 250 Cycles (min.)	CURRENT RATING	1.5 Amps
JACK INSERTION CYCLE	Over 2000 Cycles (min.)	DC RESISTANCE	0.1 ohms (max.)
OPERATION TEMPERATURE	-40 – +70 Degrees Celsius	WITHSTANDING VOLTAGE	1000 VAC RMS @ 60Hz/1min
TOLERANCE	X ± 1 .X ± 0.2 .XX ± 0.15		

© PC Cable World. All rights reserved.

PC Cable World product specifications are subject to change without notice, but are accurate at the time of printing. Please contact a sales representative for current specs. Please note that all physical specifications are nominal.

www.pccableworld.com