

ASSEMBLY PACKING LIST

Assembly Hardware

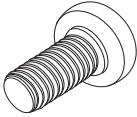

M6 Screw
x 12
(6/9/12/15/18U)

M6 Flange Nut
x 12
(6/9/12/15/18U)

Rack Screws

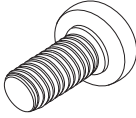

12-24 Screw
x 12
(6/9/12U)
x 24
(15/18U)

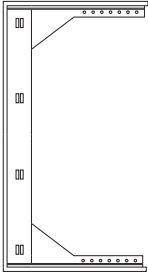

Side Bracket
x 2

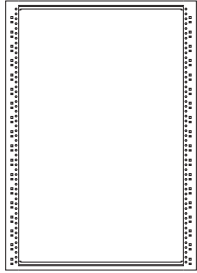

Mounting Profile
x 1



Top and Bottom Bracket
x 2

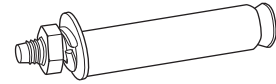

Concrete Anchors
x 4
(6/9U)
x 6
(12/15/18U)

1 Position side brackets

To start, position both side brackets parallel each other.

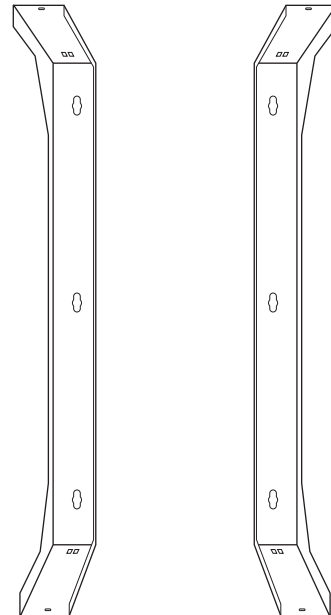

INSTALLATION

2 Adjust depth and mount top and bottom brackets

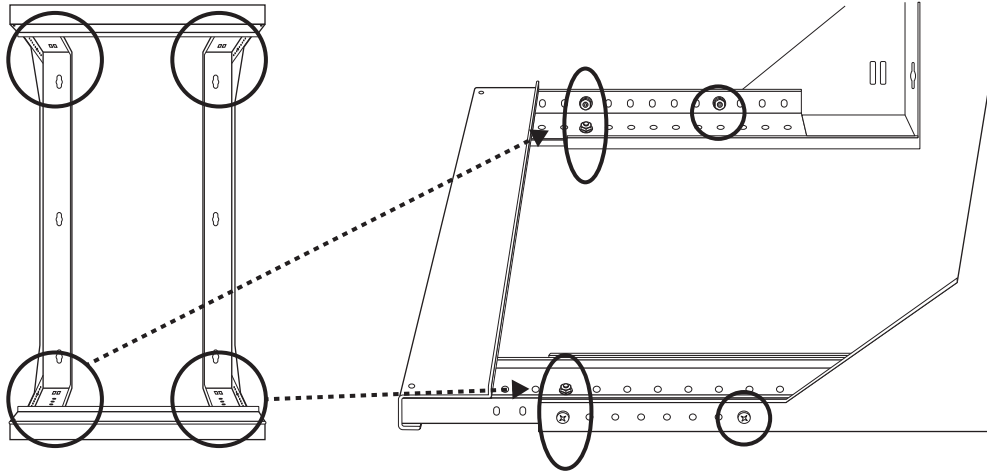

Next, find the desired depth and secure the top and bottom brackets to the side brackets using **12 x M6 screws and nuts**.

(Use 3 screws and 3 nuts for each of the four sides, like seen above)

3 Attach mounting profile to the top and bottom brackets

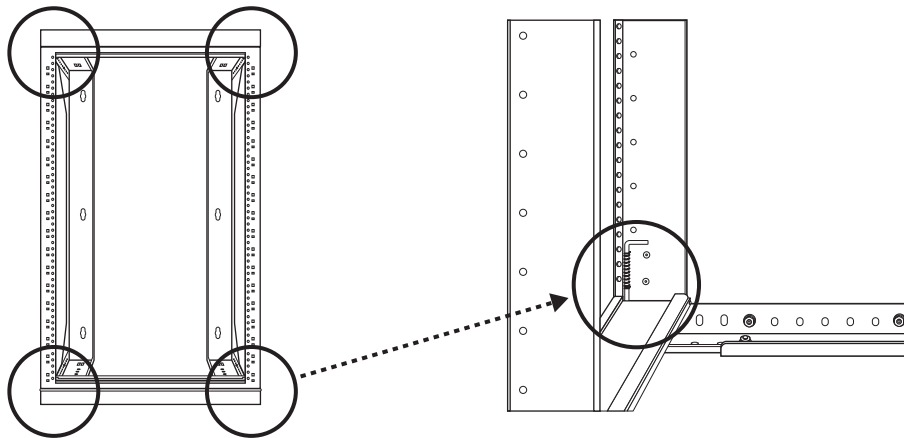

To position the mounting profile on the front opening of the frame,

1. Pull back the metal pins located on the inside of the mounting profile.
2. Align the mounting profile to the frame opening.
3. Then releasing the metal pins on all four corners into the holes on the top and bottom brackets.

Your rack is now complete.