

S6

Improve the placement of your 4- to 7-inch speakers while maintaining a low-profile desktop setup. Providing 16° of tilt, S6 desktop speaker stands are designed to angle your speakers towards your ears, ensuring you experience the full range of frequencies they have to offer. Each stand features foam padding to reduce vibration when you have the sound cranked up, and includes a mounting hole and 1/4"-20 screw to secure your YU6, TUK or other compatible speakers in place.



FEATURES & SPECIFICATIONS

- Low profile design
- 16° of vertical tilt
- Closed cell foam helps to reduce resonance
- Includes a mounting hole and 1/4"-20 screw
- Constructed out of solid steel
- Measures 7" wide by 10.6" long
- Supports up to 20 pounds
- Ideal for YU6 and TUK powered speakers
- Sold as a pair
- Gift box dimensions: 10.5" x 7.3" x 3" (26.7 cm x 18.6 cm x 7.6 cm)
- Product dimensions: 7" x 9.7" x 2.4" (17.8 x 24.7 x 6 cm)
- Product weight (pair): 6.8 lb (3.1 kg)
- UPC: 800152720012 - Black
- UPC: 800152720029 - White

COLORS



WHITE

BLACK

TECHNICAL ILLUSTRATIONS



IMPROVED SOUND

Due to their short wavelength, higher frequencies can easily go unheard unless directed towards your ears. S6 stands angle your speakers 16° upwards to ensure you capture every frequency they have to offer.

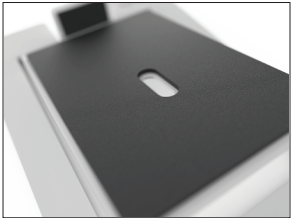

GREATER STABILITY

Using the provided 1/4"-20 screw, secure your YU6, TUK or other compatible speakers in place to prevent movement or accidental tipping.



REDUCED VIBRATION

Closed cell foam padding on the top and bottom of each stand helps to isolate your speakers and reduce undesirable resonance, ensuring your sound remains clear and uncolored.



MINIMALISTIC DESIGN

Using as little material as possible, the low-profile design of S6 speaker stands helps to keep your desktop looking clutter-free.

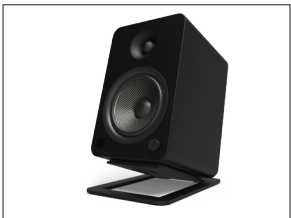

HIGH WEIGHT CAPACITY

Each stand is constructed out of 5mm solid steel in order to support up to 20 pounds. This also makes them extremely durable and resistant to vibration.

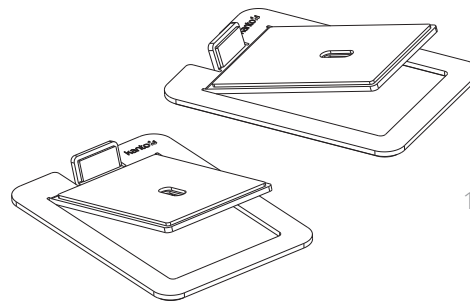

7"
17.8 cm

