

Assembly Guide

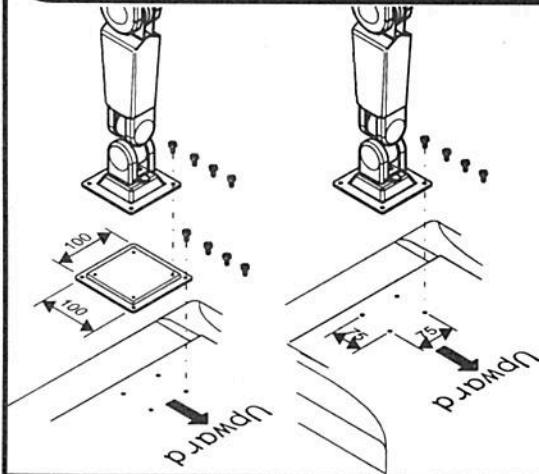

Before assembling LCD, please make sure:

- A. Knob have wedge into slot.
Two ways make sure knob wedge into slot:
 - a. Arm could not be moved
 - b. Knob shrink to normal position)
- B. Correct VESA plate specification

With 75mmx75mm VESA standard interface

Secure the arm to the rear of the LCD panel with four small screws.

With 100mmx100mm VESA standard interface

Secure 100mmx100mm plate to the arm with four small screws, then secure the arm to the rear of the LCD panel with four small screws.

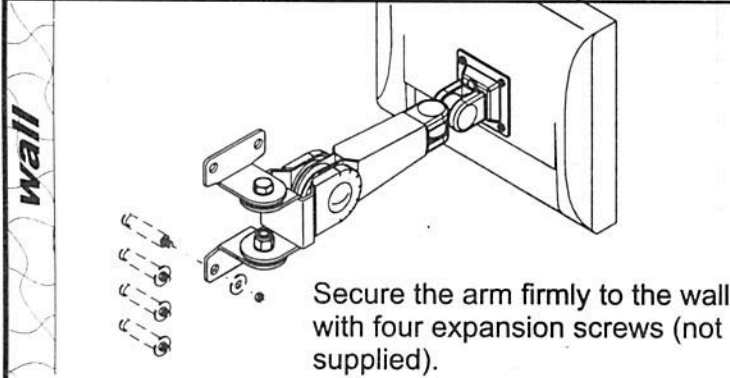

Secure the arm firmly to the wall with four expansion screws (not supplied).

Managing cables as illustrated.

The loading weight of universal joint is initially fixed below 6kgs.

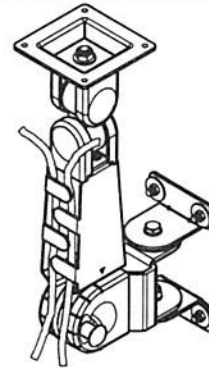

Procedure in adjusting view angle:

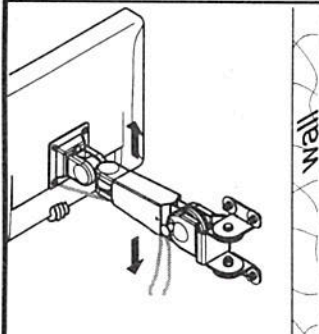

a. Support LCD monitor then slightly move arm upwards & downwards.

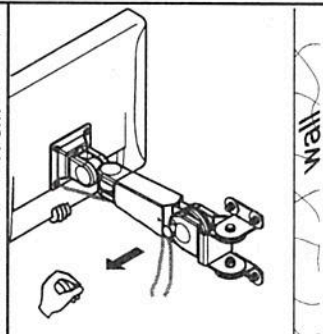

b. Pull out knob and make sure knob left slot.

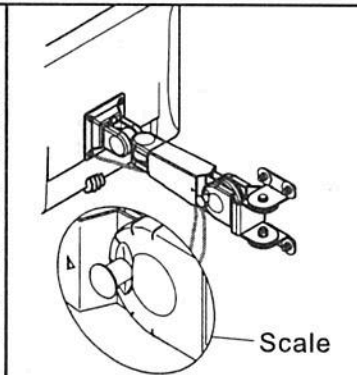

c. Pivot arm to view angle needed (aim at triangle mark) then let go of knob.

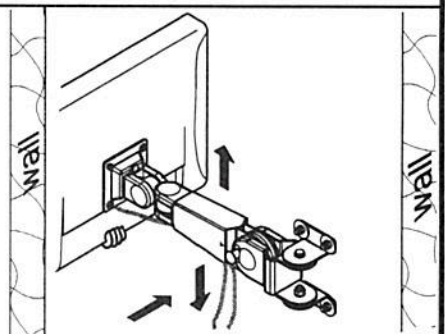

d. Move arm upwards & downwards and make sure knob have wedged into slot. Release support on LCD monitor.

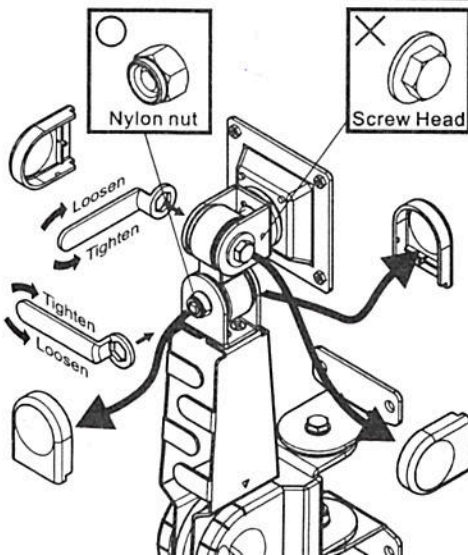

Adjusting Universal Joint Tension:

When assembling the arm with monitors of differing weights, you may find that the tension of the universal joint needs to be adjusted to ease movement or to maintain the desired monitor position. If so, adjust as follows:

- a. Remove the four plastic universal joint covers
- b. Find the nylon nut (not the screw head) and use the included wrench to adjust the tension.
- c. Use one hand to support the monitor and adjust the tension of the universal joint.
 - Clockwise : more tension
 - Counterclockwise : less tension
- d. When the desired tension is achieved, replace the four plastic covers.

Caution:

- Support the monitor during the adjustment procedure.
- Only adjust the nylon nut (not the screw head).
- Do not disassemble the universal joint

LCD Monitor Arm

Before starting assembly
Please spend some times to read this assembling and follow the procedures step by step assembly guide.

Some panels are viewed differently from the exploded drawing below. This is for extra clarity. Do not discard any of the packaging until you have checked all the parts and the package of fittings. If you are missing any of the parts, please contact the store from which you purchased your products. The staff will do their best to help you.

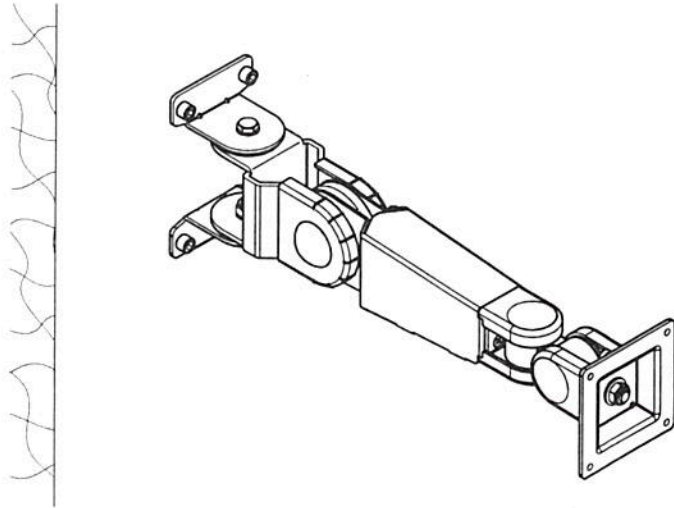

Arm Operation

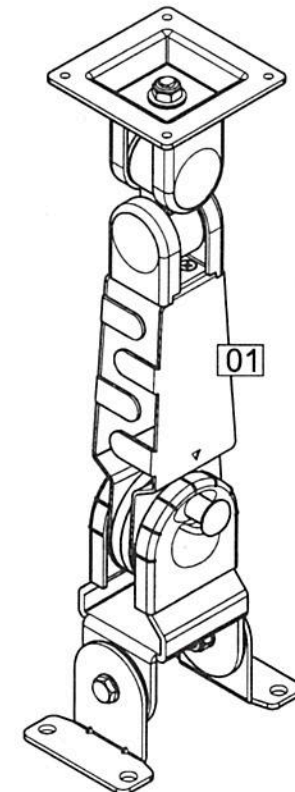
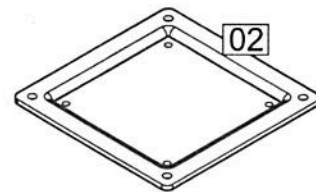
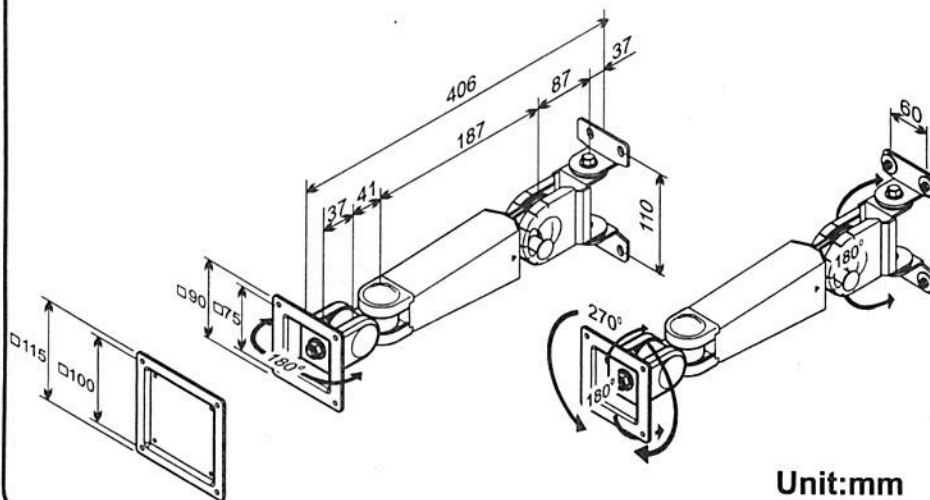

Parts Check-List

Code	Component	Qty
01	Arm	1
02	Connector Plate	1

Fitting Check-List

Code	Description	Qty
03	Screw 	8

Tools Check-List

Wrench  x1

Caution:

Regular cleaning with a clean dry cloth is usually sufficient, but for stubborn marks, wipe over gently with a clean damp cloth. Never use strong detergents or abrasive cleaners as these may damage the surface finish of your furniture. There are many small components used in the construction of this unit. These loose items should be kept away from young children while assembling your unit.