

1) Strip & prep cable (refer to the connector's instructions).

2) Open your tool all the way.

3) Insert cable into the compression sleeve support (Fig A) & slide the connector up into the adaptor head. (Fig B).

4) Rotate/adjust adaptor head until the width of the cable jacket between the compression sleeve support & the end of the connector matches the width of the compression sleeve (Fig B).

5) Squeeze/close tool until fully closed.

NOTE: Adjust adaptor head accordingly for over or under crimped results.

6) Once dialed in, set the lock washer (Fig C) to maintain the required setting.

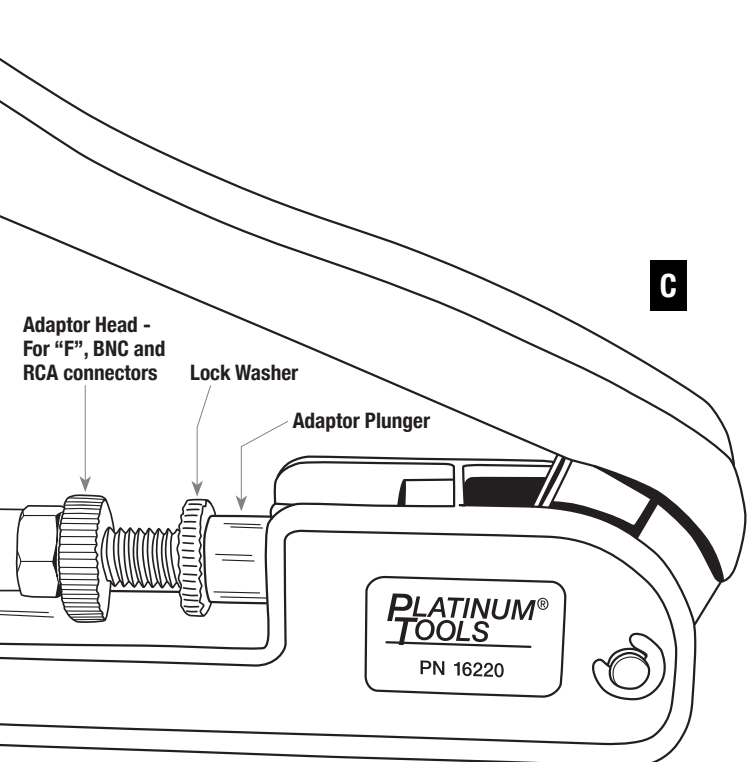
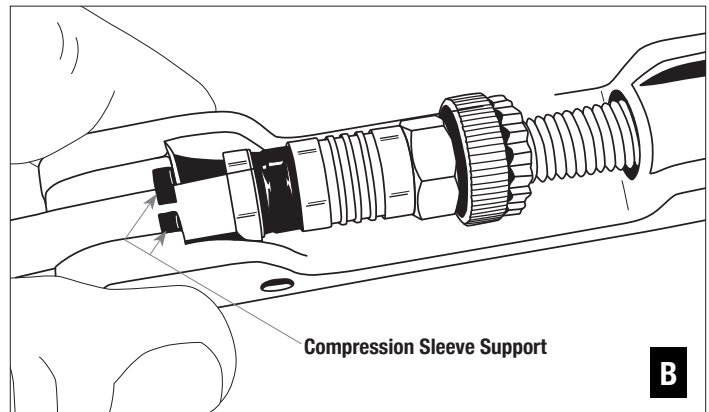
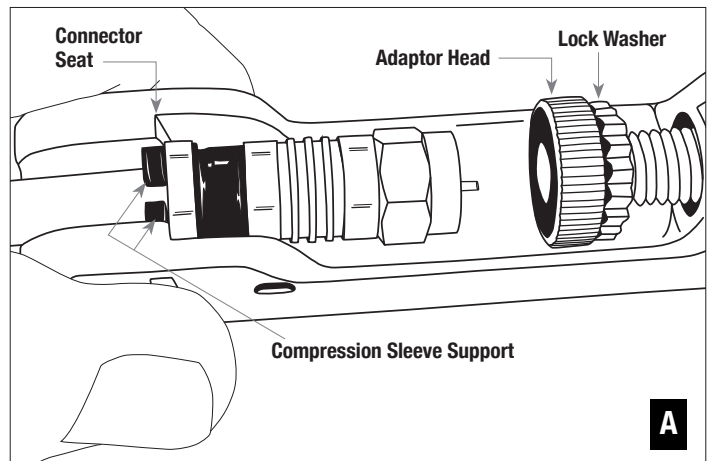

## Smart Tips:

#1 Create crimped templates of your most commonly used connectors that can be placed into the SealSmart II for quick adaptor head adjustment. Work faster without having to guess the head adjustment of your next connector job.

#2 If connector is too long to fit into SealSmart II with adaptor head wide open, remove lock washer for additional space.

